



Evaluation of the Implementation Integrated Biological System Industrial Wastewater Treatment Plant: Pollutant Removal, Operational Maintenance, Estimation of Carbon Emission

Nanik Indah Setianingsih^{*1}, Agus Purwanto², Farida Crisnaningtyas², Ikha Rasti Julia Sari²

¹National Research and Innovation Agency

²Center for Standardization and Industrial Pollution Prevention Services

ARTICLE INFO

Article history:

Received 15 August 2022

Received in revised form 16 September 2022

Accepted 19 September 2022

Available online 10 November 2022

Keywords :

Carbon emission

Integrated biological system

Pollutant removal

WWTP evaluation

ABSTRACT

The development of WWTP in business activities needs to pay attention to getting appropriate WWTP that is more valuable to support sustainable development. This study aims to evaluate two systems of integrated biological WWTP; anaerobic-wetland, and anaerobic-aerobic-wetland, including the effectiveness of pollutant removal, operational and maintenance, and estimation of carbon emissions. The performance of pollutant removal was evaluated by analyzing inlet and outlet samples of WWTP. An operational and maintenance evaluation was carried out by studying the WWTP operating system and maintenance procedures supported by a literature review. Carbon emission estimation was carried out using a formula referring to the IPCC Guidelines (2006). Organic matter removal of anaerobic-aerobic-wetland WWTP in the form of BOD₅ and COD are 92.12% and 91.72%, respectively, higher than anaerobic-wetland WWTP are 88.69% of BOD₅ and 77.62% of COD. Anaerobic-aerobic-wetland WWTP needs more maintenance and operation than anaerobic-wetland WWTP. The highest carbon emission of both WWTP is 41530.91 kgCO₂ eq/year of anaerobic-wetland WWTP from the organic matter removal process and 46485.15 kgCO₂ eq/year of anaerobic-aerobic-wetland WWTP. Electrical energy consumption emits in anaerobic-aerobic-wetland WWTP is 22338 kgCO₂ eq/year higher than anaerobic-wetland WWTP at 4299.70 kgCO₂ eq/year. Total carbon emissions of anaerobic-wetland WWTP is 47404.58 kgCO₂ eq/year and anaerobic-aerobic-wetland WWTP is 68900.23 kgCO₂ eq/year.

1. INTRODUCTION

Water and Sanitation Hygiene (WASH) is one of the crucial things to be concerned about in the world due to climate change. WASH climate-resilient development is one of the programs in realizing the Sustainable Development Goals, one of which is the construction of WASH facilities such as wastewater treatment plants (WWTP) to treat domestic and industrial wastewater. In Indonesia, the Government has required the treatment of industrial and domestic wastewater generated from every business activity

as stated in the Minister of Environment Regulation No. 68 of 2016 and P.16/Menlhk/Setjen/Kum.1/4/2019.

The development of WWTP in business activities needs to pay attention to some criteria, including selecting the right technology to treat pollutants in wastewater, investment and operational costs, the presence of by-products, and the carbon emissions generated from the wastewater treatment process. The appropriate WWTP will be more economically valuable and encourage WWTP operations' sustainability to support sustainable development.

*Correspondence author.

E-mail : amifaira497@gmail.com (Nanik Indah Setianingsih)

doi : <https://10.21771/jrtppi.2022.v13.no.2.p10-20>

2503-5010/2087-0965© 2021 Jurnal Riset Teknologi Pencegahan Pencemaran Industri-BBSPJPPPI (JRTPPPI-BBSPJPPPI).

This is an open access article under the CC BY-NC-SA license (<https://creativecommons.org/licenses/by-nc-sa/4.0/>).

Accreditation number : (Ristekdikti) 158/E/KPT/2021

Domestic and industrial wastewater generally contains high amounts of organic substances that potentially emit carbon emissions. Therefore, several technologies have been applied in treating both industrial and domestic WWTP wastewater there are chemical-physical (Mukimin et al., 2017; Vistanty et al., 2015; Crisnaningtyas and Vistanty, 2016), aerobic-anaerobic treatment (Yuliasni et al., 2017; Novarina et al., 2020), and wetlands (Moenir et al., 2014; Marlina et al., 2018).

In order to support the achievement of climate resilience, the selection of WWTP technology should follow the Climate Smart-WASH Technology criteria in the IPCC (2006). Furthermore, not only effective in degrading pollutants in wastewater, but the operated WWTP should also have minimum carbon emissions that lead to the least possible impact on climate change.

Biological WWTP can be an effective option in the treatment of wastewater from business activities, both industrial and domestic wastewater. In full-scale application, integrated biological technology has been applied to meet the requirement effluent standard (Setianingsih et al., 2021). One of the advantages is an integrated biological system capable of treating the combined wastewater (Setianingsih et al., 2020). In operation, biological WWTP is fewer chemicals than physical-chemical WWTP and does not discharge toxic & hazardous by-products (Ng. et al., 2014; Marlina et al., 2016). On the other hand, biological WWTP potentially produce carbon emissions. Therefore, the evaluation of implemented WWTP is needed to determine the effectiveness and impact on the environment to achieve the right technology in wastewater treatment. This study aims to evaluate two systems of integrated biological WWTP, including the effectiveness of pollutant removal, operational and maintenance, and estimation of carbon emissions for supporting the improvement of sustainable development and reducing global warming.

2. METHODS

This research evaluated two systems integrated biological WWTP implemented in the industrial sector,

PT. Reckitt Benckiser and Hotel Griya Persada; both wastewater treatment plants treat domestic wastewater. However, the domestic activities of PT. Reckitt Benckiser are bathroom activities, washing, and ablution, whereas the domestic activities of Hotel Griya Persada are bathroom activities, washing, catering, and ablution. Furthermore, the system of WWTP implemented at PT. Reckitt Benckiser consisted of anaerobic-wetland. Meanwhile, the system of WWTP at Hotel Griya Persada consisted of anaerobic-aerobic-wetland. The evaluation of the WWTP system is carried out by analyzing several categories, including the performance of pollutant removal, operational and maintenance of WWTP, and estimation of carbon emissions.

2.1. Performance of removal pollutant

Evaluation of pollutant removal performance was carried out of two WWTP systems by analyzing inlet and outlet samples of the WWTP with the same wastewater parameters, including pH, BOD₅, COD, TSS, oil & grease, total coliform, and MBAS.

2.2. Operational dan maintenance of WWTP

The WWTP operational and maintenance evaluation was carried out by studying the WWTP operating system and maintenance procedures, including supporting units and equipments, control parameters, the potency of by-products, additives in operational, energy use, and supported by a literature review of several biological WWTP applications.

2.3. Carbon emission estimation

Carbon emission estimation was carried out using a formula referring to the Guidelines for National Greenhouse Gas Inventories (IPCC, 2006). The primary data used were debit, organic matter removal, time of energy use, and BOD₅ effluent. Calculation of carbon emissions from the wastewater treatment sector using the IPCC Guidelines 2006 method is formulated as follows:

2.3.1. Calculation of carbon emissions from wastewater treatment processes

$$\text{Emission } CH_4 \left(\frac{kgCO_2eq}{year} \right) = Q \times (\text{organic matters}_{removed}) \times EF \times GWP_{CH_4} \times 365 \text{ day} \quad GWP_{CH_4} = 25 \quad (1)$$

$$EF = 0.131 \text{ kg}CH_4/\text{kg}COD_{removed} \quad (2)$$

$$TCOD : TBOD \text{ ratio (Blackwater and Combined Wastewater) : } 2.5 : 1 \quad (3)$$

$$EF \text{ } NO_2 = 0.16 \text{ kg } N_2O - N/\text{kg}N \quad (4)$$

2.3.2. Calculation of carbon emissions from the use of electrical energy

$$\text{Emission } CO_2 \left(\frac{kgCO_2eq}{year} \right) = \text{watt} \times \text{hour} \times EF_{CO_2} \times 10^{-3} \times 365 \text{ day} \quad (5)$$

$$EF_{CO_2} = 0.5 \text{ kg}CO_2eq/\text{kWh} \quad (6)$$

2.3.3. Calculation of carbon emissions from the effluent

$$\text{Emission } CH_4(\text{kg}CO_2eq/\text{year}) = Q \times BOD_{eff} \times EF \times GWP_{CH_4} \times 365 \text{ day} \quad (7)$$

$$\text{Emission } N_2O(\text{kg}CO_2eq/\text{year}) = Q \times 1N_{eff} \times EF \times \left(\frac{44}{28} \right) \times GWP_{N_2O} \times 365 \text{ day} \quad (8)$$

$$GWP_{N_2O} = 298 \quad (9)$$

$$EF : 0.06 \text{ kg}CH_4/\text{kg}COD_{removed} \text{ and } 0.005 \text{ kg } N_2O - N/\text{kg}N \quad (10)$$

2.3.4. Calculation of carbon emissions from sludge

$$\text{Emission } CH_4(\text{kg}CO_2eq/\text{year}) = fS_{removed} \times fS_{volume} \times EF \times GWP_{CH_4} \times 10^{-6} \times 365 \text{ day} \quad (11)$$

Annotation

Q: flow rate of wastewater

EF: emission factor

Total carbon emissions from wastewater treatment systems are (1+2+3+4) kg CO₂eq/year.

3. RESULT AND DISCUSSION

3.1. Performance of removal pollutant

The wastewater treatment plant evaluated in this study is an integrated biological system. In full-scale application, the integrated system of several treatment units is mainly applied (Tianzhi et al., 2021) to effectively achieve pollutant removal and meet the required quality standards (Kozak, Cirik, & Başak, 2021). Therefore, an analysis of pollutant removal performance was carried out to determine the ability of the WWTP system to degrade pollutants contained in wastewater. The results of performance evaluation of anaerobic-wetland and anaerobic-aerobic-wetland WWTP in degrading pollutants can be seen in table 1 and table 2.

Table 1. Performance of removal pollutant of anaerobic-wetland WWTP

No	Parameter	analysis result		%
		Inlet	Outlet	
1	BOD ₅	115	13	88.69
2	COD	240	53.7	77.62
3	TSS	66	9	86.36
4	Oil & grease	<2.38	<2.38	-
5	Total Coliform	16000	240	98.5
6	MBAS	0.8	<0.07	91.25
7	pH	7.1	7.4	

Table 2. Performance of removal pollutant of anaerobic-aerobic-wetland WWTP

No	Parameter	analysis result		% Removal
		Inlet	Outlet	
1	BOD ₅	184.3	14.52	92.12
2	COD	267.3	22.12	91.72
3	TSS	68	12	82.35
4	Oil & grease	20.21	3.99	80.25
5	Total Coliform	18000	0	100
6	MBAS	1.845	0.211	88.56
7	pH	5.7	7.1	

Table 1 and table 2 inform that the pollutant concentration of inlet wastewater treated in anaerobic-aerobic-wetland WWTP is higher in values for BOD₅, COD, TSS, and total coliform parameters than in anaerobic-wetland WWTP. For oil & grease and MBAS parameters, the pollutant concentration in the inlet sample of anaerobic-aerobic-wetland WWTP is much higher and has lower pH than the inlet sample of anaerobic-wetland WWTP. It is because, in anaerobic-aerobic-wetland WWTP, wastewater is generated from domestic activities consisting of bathroom activities, washing, ablution, and catering. Meanwhile, in anaerobic-wetland WWTP, wastewater is generated from bathroom activities, washing, and ablution only, so the value of pollutant concentration is low. Catering activity releases pollutants from food waste and dish soap that increase the concentration of COD, oil & grease, and MBAS (Doma et al., 2014). A high concentration of an organic pollutant from catering activity also affects the pH of inlet wastewater which tend to be low. The effectiveness of pollutant removal of both WWTP systems can be seen in figure 1.

Figure 1 shows the performance of WWTP systems in degrading pollutants in wastewater. Anaerobic-aerobic-wetland system has a higher percentage of BOD₅, COD, and Coliform removal than the anaerobic wetland system, which is more than 90%. For TSS and MBAS parameters, the anaerobic-wetland WWTP system has higher performance. In the anaerobic-aerobic-wetland system,

large amounts of organic matter are degraded in two stages, under anaerobic and aerobic conditions (Novarina et al., 2020; Himanshu, 2011), while in the anaerobic-wetland system, organic matter only degraded at anaerobic condition.

Most wetland units degrade nutrient-type pollutants such as ammonia, phosphorus, and residual organic substances from previous processing (Geovana et al., 2016; Moenir et al., 2014; Marlina et al., 2018; Setianingsih et al., 2021). However, the high concentration of oil & grease pollutants and MBAS will be more effectively degraded under aerobic conditions (Primasari et al., 2011). In addition, the presence of MBAS pollutant-containing surfactants is also toxic for anaerobic microbes, so it cannot be optimally treated anaerobically and must be degraded in an aerobic mechanism (Tan, K.N., 2019). The concentration of MBAS in inlet Griya Persada WWTP is higher than in inlet PT. Reckitt Benckiser which needs an aerobic unit to treat optimally.

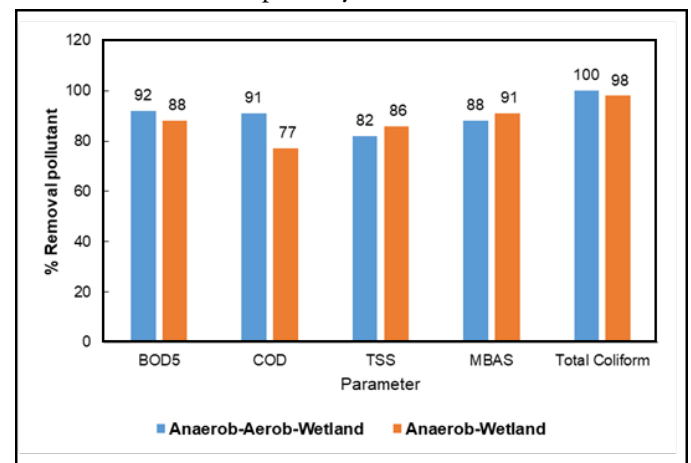
**Figure1.** Removal pollutant performance of wastewater treatment plant

3.2. Operational maintenance

Operational and maintenance evaluation of WWTP systems was carried out on some properties, as shown in table 3.

In table 3 can be seen that the WWTP system with an aerobic unit generally requires additional units, including a clarifier to settle the sludge and a drying bed to dry the excess sludge. In addition, aerobic WWTP also needs an aerator/blower to supply oxygen for microbes. Therefore,

macronutrients and micronutrients are needed for both WWTP systems. The potency of by-products in the form of sludge in WWTP with the aerobic unit is higher than in WWTP with the anaerobic unit. In conventional aerobic systems, microbial growth is high with the excess sludge reaching 30-50 percent which needs high handling costs (Wei, Y. et al., 2003).

The main control in the operation of biological WWTP is to specify wastewater flows regularly and maintain that there is no obstacle in the pipeline. The aerobic unit will be more controlled and maintained in biological WWTP. Due to aerobic microbial depending on oxygen availability, the amount of dissolved oxygen and

sludge volume index must always be controlled in addition to pH and MLSS in WWTP with an aerobic unit. Dissolved oxygen in the WWTP system with an aerobic unit must be maintained at 2 - 5 mg/L (Du, X. et al., 2018). Lack of oxygen in the WWTP aerobic system will cause negative impacts such as filamentous and bulking sludge (Martins, A.M.P, et al., 2004; D'Antoni, B.M et al., 2017). For the last operation, the energy use of the WWTP system with an aerobic unit will tend to be higher because it requires an additional aerator/blower to supply oxygen for aerobic microbes up to 1.09 kWh/m³ wastewater (Ranieri et al., 2021).

Table 3. Operational and maintenance evaluation of WWTP

No.	Properties	WWTP System		Ref
		Anaerobic-Aerobic-Wetland	Anaerobic-Wetland	
1	Additional units	Clarifier, drying bed	-	Seghezzo, L., 2004; Mulas, M. et al., 2016; Chen et al 2019
2	Equipments	Pump, blower/aerator	Pump	Seghezzo, L., 2004; Mulas, M. et al., 2016; Chen et al 2019
3	Additives	Macroµ nutrient	Macroµ nutrient	Seghezzo, L., 2004; Mulas, M. et al., 2016; Chen et al 2019
4	The potency of by-product sludge	Up to 50% in dried condition	10% in thicked condition	Seghezzo, L., 2004; Mulas, M. et al., 2016; Chen et al 2019
5	Control parameters	pH, Dissolved oxygen, MLSS, sludge volume index	pH, MLSS	Seghezzo, L., 2004; Mulas, M. et al., 2016; Chen et al 2019
6	Energy use	1.09 kWh/m ³	0.53 kWh/m ³	Seghezzo, L., 2004; Mulas, M. et al., 2016; Chen et al 2019, Ranieri et al., 2021

3.3. Carbon emission estimation

Domestic and industrial wastewater are sources of GHG emissions included in the GHG emission inventory from waste management activities according to the categories stated in the 2006 IPCC Guideline. According to Bappenas (2014), emission reductions from the waste sector have been reported by 11 provinces in Indonesia through main and supporting activities, one of which is the construction of a Wastewater Treatment Plant (WWTP). In this study, the estimation of carbon emissions in the

WWTP system was carried out at the highest pollution load during the operation of WWTP.

3.4. Carbon emission estimation of anaerobic-wetland WWTP

WWTP implemented at PT. Reckitt Benckiser was constructed with a biological system consisting of UASB anaerobic, up-flow anaerobic, and wetland, as shown in figure 2.

The energy requirement for operational WWTP comes from 1 unit of an influent pump with an operating time of 16 hours/day, 1 unit of circulation pump anaerobic, and 1 unit of circulation pump of wetland with an operating time of 24 hours/day. Influent COD was 720.0 mg/L, Effluent COD was 25.14 mg/L, and Effluent BOD₅ was

12.43 mg/L. The anaerobic-wetland system does not produce by-products in the form of sludge. Therefore, the calculation of carbon emissions from sludge management could be ignored. Calculation of carbon emissions for 50 m³/day wastewater treatment with an anaerobic-wetland system as shown in table 4, table 5, and table 6.

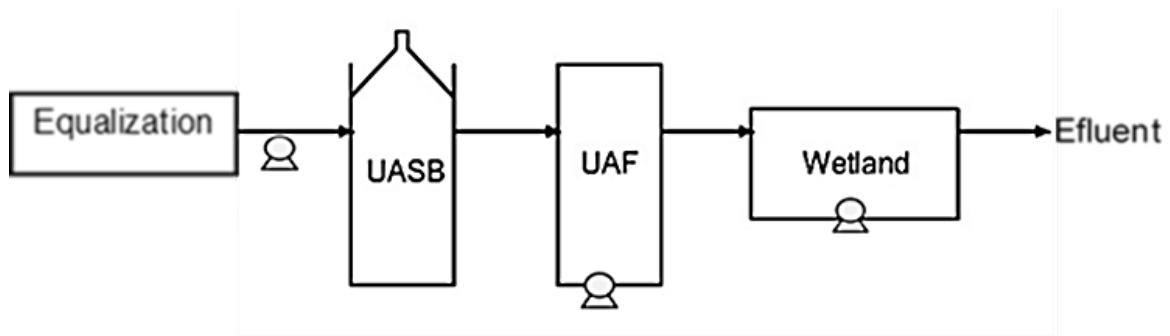

Figure 2. Anaerob-wetland WWTP system

Table 4. Carbon emissions from the wastewater treatment process

Flow rate Q (m ³ /day)	COD (kg/m ³)	EF (kg CH ₄ /kg COD _{removed})	GWP CH ₄	Time (day)	Carbon Emission (kgCO ₂ eq/year)
50	0.69486	0.131	25	365	41530.91

Table 5. Carbon emissions from the use of electrical energy

Equipment	Electrical power (Watt)	Operational time (hour)	EF (kg CO ₂)	Conversion factor	Time (day)	Carbon emission (kgCO ₂ eq/year)
Distribution pump	845	16	0.5	0.001	365	2467.40
Circulation pump I	400	24	0.5	0.001	365	1752
Circulation pump II	300	24	0.5	0.001	365	1314
Total						4299.70

Table 6. Carbon emissions from effluent

Flow rate Q (m ³ /day)	BOD ₅ (kg/m ³)	EF (kg CH ₄ /kg BOD _{5eff})	GWP CH ₄	Time (day)	Carbon emission (kgCO ₂ eq/year)
50	0.01243	0.06	25	365	340.27

Total carbon emission of anaerobic-wetland WWTP: 47404.58 kgCO₂ eq/year

3.5. Carbon emission estimation of anaerobic-aerobic-wetland WWTP

WWTP was implemented at Hotel Griya Persada, constructed with a biological system consisting of anaerobic, aerobic, and wetland units. The energy requirement for WWTP operational process comes from 1 unit influent pump, 1 unit anaerobic circulation pump, 1 unit wetland circulation pump, 1 unit clarifier circulation pump, and two unit blowers with an operating time of 24 hours/day. Influent COD was 798.4 mg/L, effluent COD was 20.65 mg/L and effluent BOD was 2.816 mg/L. Sludge in the aerobic unit is circulated with no excess microbial growth. Therefore, the calculation of carbon emissions from the sludge management element could be ignored. Anaerobic-aerobic-wetland WWTP system is shown in figure 3.

Calculation of carbon emissions for 50 m³/day wastewater treatment with an anaerobic-aerobic-wetland

system as shown in table 7, table 8, and table 9. Total carbon emission of anaerobic-aerobic-wetland WWTP: 68900.23 kgCO₂ eq/year

In biological WWTP, the source of carbon emissions comes from the anaerobic treatment. Aerobic treatment of activated sludge does not release carbon emissions but produces sludge that needs to be processed through anaerobic digestion, land disposal, and incineration. According to Purwanta W and Susanto JP. (2009), greenhouse gas emissions from waste handling activities, including methane (CH₄), nitrous oxide (N₂O), and carbon dioxide (CO₂), occurred under anaerobic conditions. The biological WWTP system used in this research does not produce sludge. Carbon emissions are estimated in wastewater treatment, electrical energy use, and WWTP effluent. Total emissions generated from each source are shown in figure 4.

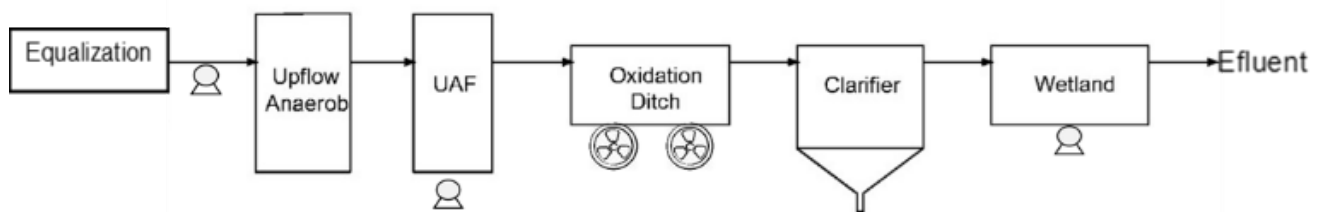

Figure 3. Anaerobic-aerobic-wetland WWTP system

Table 7. Carbon emissions from the wastewater treatment process

Flow rate Q (m ³ /day)	COD (kg/m ³)	EF (kg CH ₄ /kg COD _{removed})	GWP CH ₄	Time (day)	Carbon emission (kgCO ₂ eq/year)
50	0.77775	0.131	25	365	46485.15

Table 8. Carbon emissions from the use of electrical energy

Equipment	Electrical power (Watt)	Operational time (hour)	EF (kg CO ₂)	Conversion factor	Time (day)	Carbon emission (kgCO ₂ eq/year)
Circulation pump I	400	24	0.5	0.001	365	1752
Circulation pump I	400	24	0.5	0.001	365	1752
Circulation pump I	400	24	0.5	0.001	365	1752
Distribution pump	900	24	0.5	0.001	365	3942
Blower I	1500	24	0.5	0.001	365	6570
Blower II	1500	24	0.5	0.001	365	6570
Total						22338

Table 9. Carbon emissions from effluent

Flow rate Q (m ³ /day)	BOD ₅ (kg/m ³)	EF (kg CH ₄ /kg BOD _{5eff})	GWP CH ₄	Time (day)	Carbon emission (kgCO ₂ eq/year)
50	0.002816	0.06	25	365	77.09

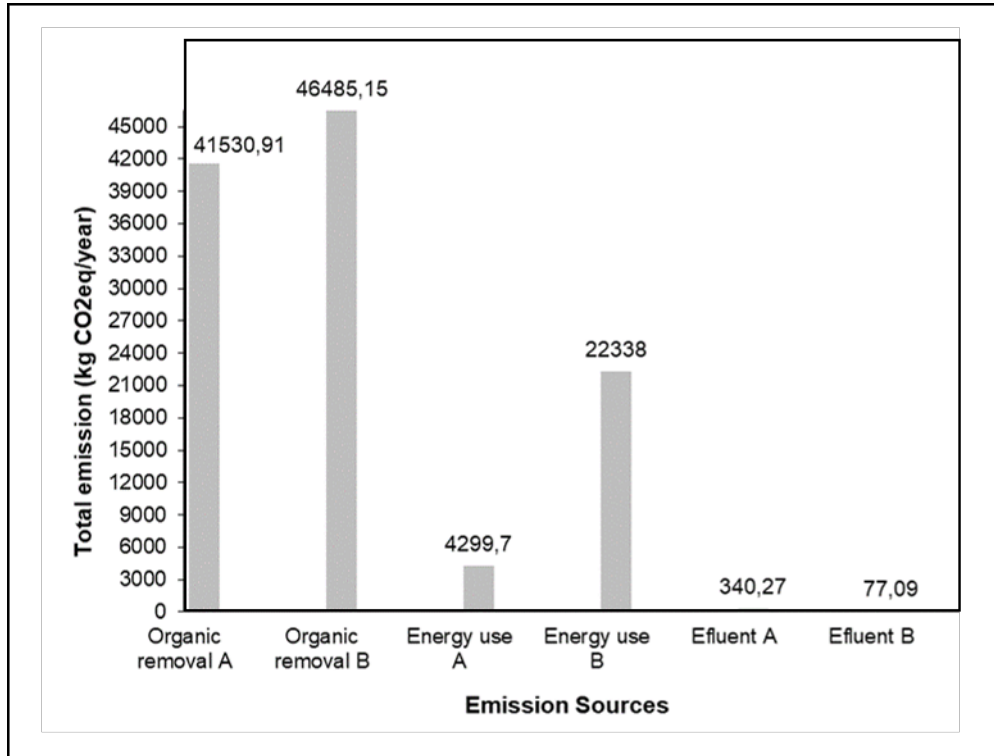

Figure 4. Carbon emission of WWTP system (A) anaerobic-wetland WWTP and (B) anaerobic-aerobic-wetland WWTP

Based on the calculation results, the total carbon emissions of anaerobic-wetland WWTP is 47404.58 kgCO₂ eq/year to treat 50 m³/day wastewater with COD influent 720.0 mg/L. Meanwhile, the total carbon emission of anaerobic-aerobic-wetland WWTP is 68900.23 kgCO₂ eq/year to treat 50 m³/day wastewater with COD influent 798.4 mg/L. The effluent from both WWTP systems meets the required quality standard with COD below 100 mg/L (Minister of Environment Regulation 2016 and 2019)

In wastewater treatment, anaerobic-wetland WWTP produces emissions of 41530.91 kgCO₂ eq/year, while anaerobic-aerobic-wetland WWTP produces emissions of 46485.15 kgCO₂ eq/year. The amount of organic matter removal determines carbon emissions in wastewater treatment. Using electrical energy, anaerobic-wetland WWTP releases emissions of 4299.70 kgCO₂ eq/year, while anaerobic-aerobic-wetland WWTP releases

emissions of 22338 kgCO₂ eq/year. In anaerobic-wetland WWTP effluent releases emissions of 340.27 kgCO₂ eq/year and anaerobic-aerobic-wetland WWTP produces emissions of 77.09 kgCO₂ eq/year.

The calculated data shows that the highest emissions from both WWTP systems are generated from the wastewater treatment process, and most of the organic matter is degraded in the anaerobic process as the primary unit in the WWTP system. Anaerobic-aerobic-wetland WWTP also emits relatively high emissions in terms of electrical energy consumption due to the use of a blower to supply oxygen for the aerobic system. The electrical energy generated from burning fossil fuels and producing emissions in the form of CO₂ and N₂O also produces (non-CO₂) GHG precursor gases such as CO, CH₄, and non-methane volatile organic compounds (NMVOC). These compounds

will be oxidized to CO₂ and gases of N₂O, NO_x, NH₃, and SO₂ (Anies et al., 2016).

Carbon emissions have been estimated on black domestic wastewater treatment systems (WASHdev, 2020). Using a conventional anaerobic system, Black domestic wastewater treatment produces emissions of 6046 kgCO₂ eq/year for 0.2 m³/day of wastewater. This value will be much higher when compared to carbon emissions in the same volume of wastewater discharged from the implementation of both WWTP systems in this study because the characteristics of wastewater affect the number of carbon emissions. Removal of organic matter in the treatment of domestic black wastewater reaches 3373.92 mg/L, much higher than the removal of organic matter in the studied WWTP system, which is 690 - 770 mg/L.

4. CONCLUSION

Anaerobic-aerobic-wetland WWTP performs higher removal of organic matter than anaerobic-wetland in the form of BOD₅ and COD for 50 m³ volume wastewater. Anaerobic-aerobic-wetland WWTP needs more maintenance and operation of an additional unit, equipment, additive, potency of sludge by-product, control parameters, and energy use than anaerobic-wetland WWTP. Carbon emission from wastewater treatment activities is influenced by the type of biological WWTP system and the level of degradation wastewater. The highest carbon emission of both WWTP resulted from the organic matter removal process, followed by electrical energy consumption and emission from effluent. For 50 m³ volume wastewater, anaerobic-wetland WWTP releases total carbon emissions of 47404.58 kgCO₂ eq/year lower than anaerobic-aerobic-wetland WWTP 68900.23 kgCO₂ eq/year.

REFERENCES

Anies Ma'rufatin, Wahyu P., Iif M.I., Diyono, Hari S. (2016). Teknologi Pengukuran Emisi Karbon Sektor Limbah. Annual Report-Pusat Teknologi Lingkungan

- Bappenas. (2014). Dua Tahun Pelaksanaan RAN-GRK Dan RAD-GRK. Laporan Ringkas
- Chen, X., Artur T.M., Kirsten H., Mikkel H.A., Dines T., Gürkan S. (2019). Assessment of Full-Scale N₂O Emission Characteristics and Testing of Control Concepts in an Activated Sludge Wastewater Treatment Plant with Alternating Aerobic and Anoxic Phases. *Environ. Sci. Technol.* 2019, 53, 21, 12485–12494. <https://doi.org/10.1021/acs.est.9b04889>
- Crisnaningtyas, F dan Hanny V. (2016). Pengolahan limbah cair industri farmasi formulasi dengan metode anaerob-aerob dan anaerob-koagulasi. *Jurnal Riset Teknologi Pencegahan Pencemaran Industri*, 7 (1) : 13-22
- D'Antoni, B.M., F. Iracà, M. Romero. (2017). Brief review on filamentous and bulking in activated sludge treatments : causes and mitigation. Technical Report. DOI: 10.13140/RG.2.2.29506.58560. available at: <https://www.researchgate.net/publication/317433584>
- Doma, Hala S., Hala M. El-Kamah and Ahmed Salem. (2014). Treatment of Catering Wastewater Using a Combination of Up-Flow Anaerobic Sludge Blanket Followed by Down Flow Hanging Sponge Reactor. *Life Science Journal* 11(12s). <http://www.lifesciencesite.com>.
- Du, X., Junlu Wang, Veeriah Jegatheesan and Guohua Shi. (2018). Dissolved oxygen control in activated sludge process using a neutral network-based adaptive PID algorithm. *Appl. Sci.* 2018, 8, 261; doi:10.3390/app8020261
- Ebie, Y., Towprayoon, S., Chiemchaisri, C., Mander, Ü., & Nogueira, S. F. (2013). Constructed Wetlands for Wastewater Treatment. *Wetlands Supplement*, 24. <http://doi.org/10.3390/w2030530>
- Geovana, P. G., Dinara, G. A., Marcos, F. J., Alexandre, L.N., Camila, F. de P., Leonardo, D. B. da S., & Antônio, C. F. de M. (2016). Removal of nitrogen and phosphorus from cattle farming wastewater

- using constructed wetland system. *African Journal of Agricultural Research*, 11(44), 4542–4550. <https://doi.org/10.5897/AJAR2016.11425>
- Handayani, NI., Rustiana Yuliasni, Nanik Indah Setianingsih, Agung Budiarto. (2020). Full Scale Application of Integrated Upflow Anaerobic Filter (UAF)-Constructed Wetland (CWs) in Small Scale Batik Industry Wastewater Treatment. *Jurnal Riset Teknologi Pencegahan Pencemaran Industri*, 11 (1), 27-35
- Henze, M., Mark CM van Loosdrecht, George A Ekama, Damir Brdjanovic. (2008). *Biological Wastewater Treatment: Principles, Modeling and Design*. IWA Publisher. ISBN: 9781843391883. DOI: 10.2166/9781780408613
- Himanshu, B. (2011). Bacterial degradation of Azo Dyes and its derivatives. Thesis PhD, Saurashtra University
- IPCC – Intergovernmental Panel on Climate Change. (2006). *IPCC Guidelines for National Greenhouse Gas Inventories*. Prepared by the National Greenhouse Gas Inventories Programme, Egglestone H.S., Buena L., Miwa K., Ngara T. and Tanabe K. (eds). Published: IGES, Japan.
- KLH – Kementerian Lingkungan Hidup. (2012). *Pedoman Penyelenggaraan Inventarisasi Gas Rumah Kaca Nasional Buku I Pedoman Umum*
- Kozak, M., Cirik, K., & Bařak, S. (2021). Treatment of textile wastewater using combined anaerobic moving bed biofilm reactor and powdered activated carbon-aerobic membrane reactor. *Journal of Environmental Chemical Engineering*, 9(4), 105596. <https://doi.org/https://doi.org/10.1016/j.jece.2021.105596>
- Lettinga, G., & Hulshoff Pol, L. (1991). UASB-Process design for various types of wastewater. *Water Science and Technology*, 24(8), 87–107.
- Marlena, B., Rustiana Y., Sartamtomo, Agung Budiarto, Syarif Arum, Misbachul Moenir, Cholid Syahroni. (2018). Removal of ammonia on catfish processing wastewater using horizontal sub-surface flow constructed wetland (HSSFCW). *Jurnal Riset Teknologi Pencegahan Pencemaran Industri*, 9 (1), 15-21
- Marlena, B., Syahroni, C., Sartamtomo, S., Zen, Nur. (2016) Pengolahan limbah organik dengan upflow anaerobic sludge blanket di industri kecap. *Jurnal Riset Teknologi Pencegahan Pencemaran Industri*, 7 (2), 81-87
- Martins, A.M.P., Krishna Pagilla, Joseph J. Heijnen, Mark C.M. van Loosdrecht. (2004). Filamentous bulking sludge—a critical review. *Water Research* 38 (2004)793817. https://www.oieau.org/eaudoc/system/files/documents/39/196194/196194_doc.pdf
- Meer, R. R. Van Der, & Vletter, R. De. (2016). Anaerobic treatment of wastewater: the gas-liquid sludge separator, 54(11), 1482–1492.
- Moenir, M., Sartamtomo, S., & Moertinah, S. (2014). Pengolahan air limbah industri teh botol dengan teknologi biologis anaerobik UASB–wetland. *Jurnal Riset Teknologi Pencegahan Pencemaran Industri*, 5(2), 59–66.
- Mulas, M., Francesco C., Jukka S., Seppo H., Riku V., (2016). Full-scale implementation of an advanced control system on a biological wastewater treatment plant. *IFAC-PapersOnLine* Volume 49, Issue 7, Pages 1163-1168. <https://doi.org/10.1016/j.ifacol.2016.07.360>
- Ng, K.K. et al., (2014). A novel application of anaerobic bio-entrapped membrane reactor for the treatment of chemical synthesis-based pharmaceutical wastewater. *Separation and Purification Technology*, 132, pp. 634-643. Available at : <http://dx.doi.org/10.1016/j.seppur.2014.06.021>
- Peraturan Daerah Provinsi Jawa Tengah No 5 Tahun 2012 Tentang Perubahan Atas Peraturan Daerah Provinsi Jawa Tengah Nomor 10 Tahun 2004 Tentang Baku Mutu Air Limbah
- Peraturan Menteri Lingkungan Hidup No. 68 Tahun 2016 Tentang Baku Mutu Air Limbah Domestik

- Permen LHK Nomor P.16/Menlhk/Setjen/Kum.1/4/2019 Tentang Perubahan Kedua Atas Peraturan Menteri Lingkungan Hidup Nomor 5 Tahun 2014
- Primasari, B., Shaliza Ibrahim, M Suffian M Annuar and Lim Xung Ian Remmie. (2011). Aerobic Treatment of Oily Wastewater: Effect of Aeration and Sludge Concentration to Pollutant Reduction and PHB Accumulation. *Proceeding World Academy of Science, Engineering and Technology*, Volume 5 No. 6. ISSN 2010-376X. Available at : <https://www.researchgate.net/publication/283070550>
- Purwanta W dan Susanto JP. (2009). Emisi GRK Sektor Sampah dan Limbah Cair Perkotaan di Indonesia. *JTekling* hal 41-47
- Ranieri, E., Silvia Giuliano, Ada Cristina Ranieri. (2021). Energy consumption in anaerobic and aerobic based wastewater treatment plants in Italy. *Water Practice and Technology* 16 (3): 851–863. <https://doi.org/10.2166/wpt.2021.045>
- Seghezzeo, L. (2004). Anaerobic treatment of domestic wastewater in subtropical regions. Thesis Wageningen University, Wageningen, the Netherlands – with references with summaries in English, Dutch, and Spanish. ISBN: 90-8504-029-9. <https://www.researchgate.net/publication/34736397>
- Setianingsih, N. I., Harsono, D., Zen, N., Crisnaningtyas, F., & Handayani, N. I. (2020). Implementasi Instalasi Pengolahan Air Limbah Biologi Terintegrasi Untuk Mengolah Air Limbah Campuran Domestik Dan Produksi. In *Seminar Nasional Teknologi Industri Hijau* (Vol. 2, No. 1, pp. 159-168).
- Setianingsih, N.I., Sartamtomo, Harsono, D. (2021). Desain Instalasi Pengolahan Air Limbah Domestik Dengan Sistem Biologi Anaerob-Wetland. In *Seminar Nasional Sains and Entrepreneurship* (Vol. 1, No. 1, SNSE : VII). <http://conference.upgris.ac.id/index.php/snse/article/view/2100>
- Tan, K.N. (2019). A Detergent Destruction Method Used for Aerobic Treatment of Wastewater High in Detergent Content (WHD). *International Journal of Environmental Science and Development* 10(8):236-240
DOI:10.18178/ijesd.2019.10.8.1179
- Tianzhi, W., Weijie, W., Hongying, H., & Khu, S.-T. (2021). Effect of coagulation on bio-treatment of textile wastewater: Quantitative evaluation and application. *Journal of Cleaner Production*, 312, 127798. <https://doi.org/https://doi.org/10.1016/j.jclepro.2021.127798>
- Vistanty H, Aris M, Novarina IH. (2015). Pengolahan Air Limbah Industri Karton Box dengan Metode Integrasi Upflow Anaerobic Sludge Bed (UASB) Reactor dan Elektrokoagulasi-Flotasi. *Jurnal Riset Teknologi Pencegahan Pencemaran Industri*. Vol. 6, No.1.DOI: <http://dx.doi.org/10.21771/jrtppi.2015.v6.no1.p1%20-%208>
- Wei, Y., Renze T. Van Houten , Arjan R. Borger, Dick H. Eikelboom, Yaobo Fan. (2003). Minimization of excess sludge production for biological wastewater treatment. *Water Research* 37(18):4453-67. DOI:10.1016/S0043-1354(03)00441-X
- Yuliasni, R., N.I. Setyaningsih, N.I. Handayani, A. Budiarto. (2017) The performance of combined technology Upflow anaerobic reactor (UAR)-activated sludge (AS) for treating batik wastewater, *Adv. Sci. Lett.* 23. <https://doi.org/10.1166/asl.2017.8725>